

Multi-objective Optimization for Pricing System Security in Electricity Markets

F. Milano, *Student Member, IEEE*, Claudio A. Cañizares, *Senior Member, IEEE*,
and M. Invernizzi

Abstract—This paper proposes a novel technique for representing system security in the operations of decentralized electricity markets, with special emphasis on voltage stability. An Interior Point Method is used to solve the Optimal Power Flow problem with a multi-objective function for maximizing both social benefit and the distance to maximum loading conditions. A 6-bus system with both supply and demand-side bidding is used to illustrate the proposed technique for both elastic and inelastic demand, and a 129-bus test system that models the Italian HV transmission network is used for testing the practical applicability of the proposed method. The results obtained show that the proposed technique is able to improve system security while yielding better market conditions through increased transaction levels and improved locational marginal prices throughout the system.

Keywords—Electricity markets, locational marginal prices, maximum loadability, security, multi-objective optimization.

I. INTRODUCTION

IN recent years, the electricity industry has undergone drastic changes due to a world wide deregulation/privatization process that has significantly affected energy markets. With past and current difficulties in building new transmission lines and the significant increase in power transactions associated with competitive electricity markets, maintaining system security is more than ever one of the main concerns for market and system operators. Hence, there is a need for pricing this security in a simple, unambiguous and transparent way, so that the “right” market signals can be conveyed to all market participants. However, pricing security is not an easy task, since it involves a variety of assumptions as well as complex models and simulations. In the three main market models that have been proposed, i.e. centralized markets, standard auction markets and spot pricing or hybrid markets, how to properly include system security is still an open question. This paper mainly focuses on hybrid markets and on the inclusion of proper security constraints through the use of a multi-objective Optimal Power Flow (OPF) based approach, which is solved by means of a logarithmic barrier Interior-Point Method (IPM).

In [1], several strategies were proposed for an OPF with active power dispatching and voltage security (represented

only by voltage limits) using an IPM that proved to be robust, especially in large networks, as the number of iterations increase slightly with the number of constraints and network size. The early implementations of IPM for solving market problems, accounting somewhat for system security, were limited to the use of linear programming [2]. In [3] and [4], the authors present a comprehensive investigation of the use of IPM for non-linear problems, and describe the application of Merhotra’s predictor-corrector to the OPF, which highly reduces the number of iterations to obtain the final solution. Non-linear optimization techniques have also been shown to be adequate for addressing a variety of voltage stability issues, such as the maximization of the loading parameter in voltage collapse studies, as discussed in [5], [6], [7] and [8]. In [9] and [10], non-linear IPM techniques are applied to the solution of diverse OPF market problems. Finally, in [11], the authors proposed a technique to account for system security through the use of voltage stability based constraints in an OPF-IPM market representation, so that security is not simply modeled through the use of voltage and power transfer limits, typically determined off-line, but it is properly represented in on-line market computations. In the current paper, a multi-objective approach similar to the one proposed in [8] is used in an OPF-IPM market model, so that the social benefit and the distance to a maximum loading condition are maximized at the same time. In this case, voltage stability concepts and techniques are used to improve the representation of system security.

The paper is organized as follows: Section II presents the basic concepts on which the proposed methodology is based, discussing briefly how transmission system congestion is represented in the proposed models; the use of Locational Marginal Prices (LMPs) to determine the cost of system security is also discussed in this section. In Section III, the use of the proposed technique is illustrated in a 6-bus test system with elastic and inelastic demand, and in a realistic 129-bus test system based on a model of the Italian HV transmission network assuming elastic demand bidding. For both test systems, results are compared with respect to solutions obtained with a standard OPF-based market technique. Finally, Section IV discusses the main contributions of this paper as well as possible future research directions.

II. MULTI-OBJECTIVE OPF WITH VOLTAGE STABILITY CONSTRAINTS

The OPF-based approach is basically a non-linear constrained optimization problem, and consists of a scalar ob-

Submitted to *IEEE Trans. Power Systems*, March 2002, resubmitted November 2002.

F. Milano and M. Invernizzi are with the Dept. of Electrical Engineering, University of Genoa, Genoa, 16145, Italy (e-mail: fmilano@epsl.die.unige.it).

C. A. Cañizares is with the Dept. of Electrical & Computer Engineering, University of Waterloo, Waterloo, ON, N2L-3G1, Canada (e-mail: c.canizares@ece.uwaterloo.ca).

jective function and a set of equality and inequality constraints. A typical OPF-based market model can be represented using the following security constrained optimization problem (e.g. [12]):

$$\begin{aligned}
\text{Min.} \quad & -(C_D^T P_D - C_S^T P_S) && \rightarrow \text{Social benefit} & (1) \\
\text{s.t.} \quad & f(\delta, V, Q_G, P_S, P_D) = 0 && \rightarrow \text{PF equations} \\
& 0 \leq P_S \leq P_{S_{\max}} && \rightarrow \text{Sup. bid blocks} \\
& 0 \leq P_D \leq P_{D_{\max}} && \rightarrow \text{Dem. bid blocks} \\
& |P_{ij}(\delta, V)| \leq P_{ij_{\max}} && \rightarrow \text{Power transfer lim.} \\
& |P_{ji}(\delta, V)| \leq P_{ji_{\max}} && \\
& I_{ij}(\delta, V) \leq I_{ij_{\max}} && \rightarrow \text{Thermal limits} \\
& I_{ji}(\delta, V) \leq I_{ji_{\max}} && \\
& Q_{G_{\min}} \leq Q_G \leq Q_{G_{\max}} && \rightarrow \text{Gen. } Q \text{ lim.} \\
& V_{\min} \leq V \leq V_{\max} && \rightarrow V \text{ "security" lim.}
\end{aligned}$$

where C_S and C_D are vectors of supply and demand bids in \$/MWh, respectively; Q_G stand for the generator reactive powers; V and δ represent the bus phasor voltages; P_{ij} and P_{ji} represent the power flowing through the lines in both directions, and are used to model system security by limiting the transmission line power flows, together with line current I_{ij} and I_{ji} thermal limits and bus voltage limits; and P_S and P_D represent bounded supply and demand power bids in MW. In this model, which is typically referred to as a security constrained OPF, P_{ij} and P_{ji} limits are obtained by means of off-line angle and/or voltage stability studies. In practice, these limits are usually determined based only on power flow based voltage stability studies [13]. Hence, these limits do not actually represent the actual stability conditions of the resulting solution, which may lead in some cases to insecure solutions and/or inadequate price signals, as demonstrated in this paper.

A. Proposed OPF Market Model

In this paper, the following optimization problem is proposed to represent an OPF market model, based on what has been proposed in [7], [8], [11], so that system security is better modeled through the use of voltage stability conditions:

$$\begin{aligned}
\text{Min.} \quad & G = -\omega_1(C_D^T P_D - C_S^T P_S) - \omega_2 \lambda_c & (2) \\
\text{s.t.} \quad & f(\delta, V, Q_G, P_S, P_D) = 0 & \rightarrow \text{PF equations} \\
& f(\delta_c, V_c, Q_{G_c}, \lambda_c, P_S, P_D) = 0 & \rightarrow \text{Max load PF eqs.} \\
& \lambda_{c_{\min}} \leq \lambda_c \leq \lambda_{c_{\max}} & \rightarrow \text{loading margin} \\
& 0 \leq P_S \leq P_{S_{\max}} & \rightarrow \text{Sup. bid blocks} \\
& 0 \leq P_D \leq P_{D_{\max}} & \rightarrow \text{Dem. bid blocks} \\
& I_{ij}(\delta, V) \leq I_{ij_{\max}} & \rightarrow \text{Thermal limits} \\
& I_{ji}(\delta, V) \leq I_{ji_{\max}} & \\
& I_{ij}(\delta_c, V_c) \leq I_{ij_{\max}} & \\
& I_{ji}(\delta_c, V_c) \leq I_{ji_{\max}} & \\
& Q_{G_{\min}} \leq Q_G \leq Q_{G_{\max}} & \rightarrow \text{Gen. } Q \text{ limits} \\
& Q_{G_{\min}} \leq Q_{G_c} \leq Q_{G_{\max}} &
\end{aligned}$$

$$\begin{aligned}
V_{\min} \leq V \leq V_{\max} & \rightarrow V \text{ "security" lim.} \\
V_{\min} \leq V_c \leq V_{\max} &
\end{aligned}$$

In this case, a second set of power flow equations and constraints with a subscript c is introduced to represent the system at the limit or "critical" conditions associated with the maximum loading margin λ_c in p.u., where λ is the parameter that drives the system to its maximum loading condition. The maximum or critical loading point could be either associated with a thermal or bus voltage limit or a voltage stability limit (collapse point) corresponding to a system singularity (saddle-node bifurcation) or system controller limits like generator reactive power limits (limit induced bifurcation) [14], [15]. Thus, for the current and maximum loading conditions, the generator and load powers are defined as follows:

$$\begin{aligned}
P_G &= P_{G_0} + P_S & (3) \\
P_L &= P_{L_0} + P_D \\
P_{G_c} &= (1 + \lambda_c + k_{G_c})P_G \\
P_{L_c} &= (1 + \lambda_c)P_L
\end{aligned}$$

where P_{G_0} and P_{L_0} stand for generator and load powers which are not part of the market bidding (e.g. must-run generators, inelastic loads), and k_{G_c} represents a scalar variable used to distribute the system losses associated *only* with the solution of the critical power flow equations in proportion to the power injections obtained in the solution process, i.e. a standard distributed slack bus model is used. It is assumed that the losses corresponding to the maximum loading level defined by λ_c in (2) are distributed among all generators; other possible mechanisms to handle increased losses could be implemented, but they are beyond the main interest of the present paper.

In the proposed OPF-based approach, λ_c represents the maximum loadability of the network and, hence, this value can be viewed as a measure of the congestion of the network, which is represented here using the following Maximum Loading Condition (MLC) definition:

$$\text{MLC} = (1 + \lambda_c) \Sigma P_{D_i} \quad (4)$$

In the computation of λ_c , contingencies are not considered. (Their inclusion is beyond the scope of this paper. However, in the literature, a few approaches have been proposed to include contingencies in voltage stability constrained OPF that could be considered in the OPF formulation proposed in this paper; for example, the heuristic method discussed in [16].)

In the multi-objective function G , two terms are present, with their influence on the final solution being determined by the value of the weighting factors ω_1 and ω_2 ($\omega_1 > 0$, $\omega_2 > 0$). The first term represents the social benefit, whereas the second term guarantees that the "distance" between the market solution and the critical point is maximized [7]. Observe that $\omega_1 > 0$, since for $\omega_1 = 0$ there would be no representation of the market in the proposed OPF formulation, rendering it useless. Furthermore,

$\omega_2 > 0$, otherwise λ_c will not necessarily correspond to a maximum loading condition of the system. Notice that the two terms of the objective function are expressed in different units, since the social benefit would be typically in \$/h, whereas the ‘‘security’’ term would be in p.u., which will basically affect the chosen values of ω_1 and ω_2 (typically, $\omega_1 \gg \omega_2$). However, it is possible to assume that $\omega_1 = (1 - \omega)$ and $\omega_2 = \omega$, with proper scaled values of ω for each system under study ($0 < \omega < 1$), as this simplifies the optimization problem without losing generality.

Equations (2) and (3) are for elastic demand. In the case of a pure inelastic demand, P_D is known, and this can be represented in these equations by setting $C_{D_i} = 0$ and $P_{D_i} = P_{D_i \max}$; hence the problem basically becomes the same as the one analyzed in [11]. In this case, one must be aware that the associated OPF problem may have no solution, as the system may not be able to supply the required demand.

Boundaries for the loading margin λ_c have been included in (2) based on practical considerations. Thus, the minimum limit $\lambda_{c \min}$ is introduced in order to ensure a minimum level of security in any operating condition and for any value of ω , where the maximum value $\lambda_{c \max}$ imposes a maximum required security level. These conditions ensure that the loading parameter remains within certain limits to avoid solutions of (2) characterized by either low security levels ($\lambda_c < \lambda_{c \min}$) or low supply and demand levels ($\lambda_c > \lambda_{c \max}$), which would be unacceptable.

B. Locational Marginal Prices

It is widely recognized that spot pricing through marginal costs can provide reliable pricing indicators [12]. OPF-based market models have the advantage of producing not only the optimal operating point solutions, but also a variety of sensitivity variables through the Lagrangian multipliers, which can be associated with Locational Marginal Prices (LMPs) at each node.

The Lagrangian multipliers associated with (2) correspond to the standard definition of LMPs only when $\omega = 0$, i.e. for a pure market model. Lagrangian multipliers for $\omega > 0$ would lead to unrealistic results, since they decrease almost linearly with respect to increases in ω . Hence, LMPs which are not dependent of ω are needed.

Consider the following vector objective function:

$$\bar{G} = \begin{bmatrix} -(C_D^T P_D - C_S^T P_S) \\ -\lambda_c \end{bmatrix} \quad (5)$$

From a fundamental theorem of multi-objective optimization [17], an optimal solution of (2) is also a Pareto optimal point for the minimization problem constituted by the objective function (5) plus the constraints defined in (2). Thus, an optimal solution point of (2) has the property of independently minimizing both terms of the objective function (5). Based on this premise, for a given value of the weighting factor, say ω^* , an IPM is first used to minimize the following Lagrangian function of (2):

$$\text{Min. } \mathcal{L} = G - \rho^T f(\delta, V, Q_G, P_S, P_D) \quad (6)$$

$$\begin{aligned} & - \rho_c^T f(\delta_c, V_c, Q_{G_c}, \lambda_c, P_S, P_D) \\ & - \mu_{\lambda_{c \max}} (\lambda_{c \max} - \lambda_c - s_{\lambda_{c \max}}) \\ & - \mu_{\lambda_{c \min}} (\lambda_c - s_{\lambda_{c \min}}) \\ & - \mu_{P_{S \max}}^T (P_{S \max} - P_S - s_{P_{S \max}}) \\ & - \mu_{P_{S \min}}^T (P_S - s_{P_{S \min}}) \\ & - \mu_{P_{D \max}}^T (P_{D \max} - P_D - s_{P_{D \max}}) \\ & - \mu_{P_{D \min}}^T (P_D - s_{P_{D \min}}) \\ & - \mu_{I_{ij \max}}^T (I_{\max} - I_{ij} - s_{I_{ij \max}}) \\ & - \mu_{I_{ji \max}}^T (I_{\max} - I_{ji} - s_{I_{ji \max}}) \\ & - \mu_{I_{jic \max}}^T (I_{\max} - I_{jic} - s_{I_{jic \max}}) \\ & - \mu_{I_{jic \max}}^T (I_{\max} - I_{jic} - s_{I_{jic \max}}) \\ & - \mu_{Q_{G \max}}^T (Q_{G \max} - Q_G - s_{Q_{G \max}}) \\ & - \mu_{Q_{G \min}}^T (Q_G - Q_{G \min} - s_{Q_{G \max}}) \\ & - \mu_{Q_{G_c \max}}^T (Q_{G \max} - Q_{G_c} - s_{Q_{G_c \max}}) \\ & - \mu_{Q_{G_c \min}}^T (Q_{G_c} - Q_{G \min} - s_{Q_{G_c \max}}) \\ & - \mu_{V_{\max}}^T (V_{\max} - V - s_{V_{\max}}) \\ & - \mu_{V_{\min}}^T (V - V_{\min} - s_{V_{\min}}) \\ & - \mu_{V_{c \max}}^T (V_{\max} - V_c - s_{V_{c \max}}) \\ & - \mu_{V_{c \min}}^T (V_c - V_{\min} - s_{V_{c \min}}) - \mu_s \left(\sum_i \ln s_i \right) \end{aligned}$$

where $\mu_s \in \mathfrak{R}$, $\mu_s > 0$, is the barrier parameter, and ρ and $\rho_c \in \mathfrak{R}^n$, and all the other μ ($\mu_i > 0, \forall i$) correspond to the Lagrangian multipliers. The s variables form the slack vector whose non-negativity condition ($s_i > 0, \forall i$) is ensured by including the logarithmic barrier terms $\sum_i \ln s_i$. The solution of (6) provides the value of λ_c^* associated with ω^* , along with all other system variables and market bids.

For the following OPF:

$$\text{Min. } \hat{G} = -(C_D^T P_D - C_S^T P_S) \quad (7)$$

with the same constraints as in (2), and loading parameter fixed at $\lambda_c = \lambda_c^*$, the solution of (2) is also a solution of (7), i.e. the vector of voltage phases and magnitudes (θ, V, θ_c and V_c), generator reactive powers (Q_G and Q_{G_c}), power bids (P_S and P_D), the loss distribution factor (k_{G_c}) and the loading parameter (λ_c) are identical for both (2) and (7). Observe that the value of λ_c cannot be obtained by the mere solution of (7), as its value is basically defined by the value of ω in the multi-objective problem (2). As a result, the weighting factor ω , although it affects the solution and the dual variables of (7), it does not explicitly appear in the equations; thus, the Lagrangian multipliers of the power flow equations in (7) can be associated with the system LMPs, and can be derived from applying the corresponding KKT optimality conditions as follows:

$$\partial \hat{\mathcal{L}} / \partial P_{S_i} = C_{S_i} - \rho_{P_{S_i}} + \mu_{P_{S_{\max_i}}} - \mu_{P_{S_{\min_i}}} \quad (8)$$

$$- \rho_{c P_{S_i}} (1 + \lambda_c^* + k_{G_c}^*) = 0$$

$$\partial \hat{\mathcal{L}} / \partial P_{D_i} = -C_{D_i} + \rho_{P_{D_i}} + \rho_{Q_{D_i}} \tan(\phi_{D_i})$$

$$\begin{aligned}
& + \mu P_{D_{\max_i}} - \mu P_{D_{\min_i}} + \rho_c P_{D_i} (1 + \lambda_c^*) \\
& + \rho_c Q_{D_i} (1 + \lambda_c^*) \tan(\phi_{D_i}) = 0
\end{aligned}$$

where $\widehat{\mathcal{L}}$ is the Lagrangian of (7) and ϕ_{D_i} represents a constant load power factor angle. Thus, the LMPs can be defined as

$$\begin{aligned}
\text{LMP}_{S_i} &= \rho_{P_{S_i}} = C_{S_i} + \mu P_{S_{\max_i}} - \mu P_{S_{\min_i}} \\
&\quad - \rho_c P_{S_i} (1 + \lambda_c^* + k_{G_c}^*) \\
\text{LMP}_{D_i} &= \rho_{P_{D_i}} = C_{D_i} + \mu P_{D_{\min_i}} - \mu P_{D_{\max_i}} \\
&\quad - \rho_c P_{D_i} (1 + \lambda_c^*) - \rho_c Q_{D_i} (1 + \lambda_c^*) \tan(\phi_{D_i}) \\
&\quad - \rho Q_{D_i} \tan(\phi_{D_i})
\end{aligned} \tag{9}$$

From this definition, the LMPs are directly related to the costs C_S and C_D , and do not directly depend on the weighting factor ω . These LMPs have additional terms associated with λ_c^* which represent the added value of the proposed OPF technique. If a maximum value $\lambda_{c_{\max}}$ is imposed on the loading parameter, when the weighting factor ω reaches a value, say ω_0 , at which $\lambda_c = \lambda_{c_{\max}}$, there is no need to solve other OPFs for $\omega > \omega_0$, since the security level cannot increase any further.

Observe that the computation of these LMPs is quite inexpensive, since the optimal point is already known from the solution of (2), thus the determination of the Lagrangian multipliers ρ is basically reduced to solving a set of linear equations.

III. EXAMPLES

In the following subsections, the OPF problem (2) and the proposed technique for computing LMPs are applied to a 6-bus test system and to a 129-bus model of the Italian HV transmission system. The results of optimization technique (1) are also discussed to observe the effect of the proposed method in the LMPs and system security, which is represented here through the MLC. The power flow limits needed in (1) were obtained “off-line” by means of a continuation power flow technique [14]. For both test systems, bid load and generator powers were used as the direction needed to obtain a maximum loading point and the associated power flows in the lines, ignoring contingencies, so that proper comparisons can be made. All the results discussed here were obtained in MATLAB using a primal-dual IP method based on a Mehrotra’s predictor-corrector technique [4].

For both test cases, the limits of the loading parameter were assumed to be $\lambda_{c_{\min}} = 0.1$ and $\lambda_{c_{\max}} = 0.8$, i.e. for any value of ω , it is assumed that the system can be securely loaded to an MLC between 110% and 180% of the total transaction level of the given solution. To allow for adequate comparisons, the actual power flow limits used in (1) were reduced by 10% with respect to the values obtained from the off-line continuation power flow analysis to emulate the $\lambda_c = 0.1$ limit.

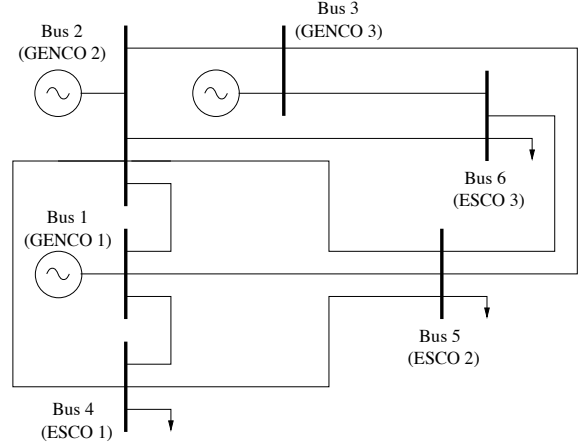

Fig. 1. 6-bus test system.

A. 6-bus Test Case

Figure 1 depicts the 6-bus test case, which is extracted from [18], representing three generation companies (GENCOs) and three energy supply companies (ESCOs) that provide supply and demand bids, respectively. (The complete data set for this system is provided in the Appendix, so that the results discussed here may be readily reproduced.)

Results for the OPF formulation (1) are reported in Table I; the MLC value in this table was computed off-line using the generator voltages and load and generation power directions obtained from the OPF solution. Table II, on the other hand, shows the solution obtained for the proposed multi-objective OPF (2) for $\omega = 10^{-3}$, which is referred to here as VS-constrained OPF, since the distance to the maximum loading point is not being really “optimized”, with mostly the social benefit being considered in the objective function. For both solutions, generator voltages are at their maximum limits, as expected, since this condition generally provides higher transactions levels. However, in comparison with the standard OPF approach based on “security” limits determined off-line, the solution of the proposed method provides better LMPs, a higher total transaction level T ($T = \sum_i P_{L_i}$) and higher MLC, which demonstrates that off-line power flow limits are not adequate constraints for representing the actual system congestion. The improved LMPs result also in a lower total price paid to the Independent Market Operator (Pay_{IMO}), i.e. the network congestion prices are lower, even though the system losses are higher (which is to be expected, as T is higher).

Figure 2 shows the effect of the weighting factor ω in the total transaction level T and the maximum loading margin λ_c . Observe that, as expected, the more the weight of security, the higher the security level λ_c , but, at the same time, the lower the transaction level T . This is due to the power bids being free to vary so that, as ω increases, congestion is minimized (security is maximized) by both increasing λ_c and reducing T .

Figure 3 depicts power bids and LMPs as ω varies, illustrating the transition from an OPF market problem to

TABLE I

6-BUS TEST SYSTEM: OPF WITH OFF-LINE POWER FLOW LIMITS

Participant	V [p.u.]	ρ [\$/MWh]	P_{BID} [MW]	P_0 [MW]	Pay [\$/h]
GENCO 1	1.100	9.70	14.4	90	-1013
GENCO 2	1.100	8.80	2.4	140	-1253
GENCO 3	1.084	8.28	20.0	60	-663
ESCO 1	1.028	11.64	15.6	90	1229
ESCO 2	1.013	10.83	0.0	100	1083
ESCO 3	1.023	9.13	20.0	90	1005
TOTALS	$T = 315.6$ MW Losses = 11.2 MW		$\text{Pay}_{\text{IMO}} = 388$ \$/h MLC = 520 MW		

TABLE II

6-BUS TEST SYSTEM: VS-CONSTRAINED OPF

Participant	V [p.u.]	ρ [\$/MWh]	P_{BID} [MW]	P_0 [MW]	Pay [\$/h]
GENCO 1	1.100	8.94	0.0	90	-805
GENCO 2	1.100	8.91	25.0	140	-1470
GENCO 3	1.100	9.07	20.0	60	-726
ESCO 1	1.021	9.49	25.0	90	1091
ESCO 2	1.013	9.57	10.0	100	1053
ESCO 3	1.039	9.35	8.0	90	916
TOTALS	$T = 323$ MW Losses = 12.0 MW		$\text{Pay}_{\text{IMO}} = 59$ \$/h MLC = 539 MW		

an OPF security problem as λ_c approaches its maximum imposed value of $\lambda_{c_{\max}} = 0.8$. Observe how the LPMs in this example decrease as the security levels increase, since the auction solutions move away from the security limits, i.e. the system is less congested. Furthermore, even though the LMPs and the overall total transaction level decrease, local bids may increase or decrease, accordingly to the power schedule which better matches the obtained loading margin. For example, Fig. 4 depicts the LMP at Bus 6 as a function of the power demand of ESCO 3 at that bus with respect to the value of the weighting factor ω , illustrating that the relationship between system security and bids is not obvious and very much depends on the chosen security limits; in other words, as ω increases, i.e. as system security becomes more significant in the optimization problem, the price-power pair does not show any obvious relationship with respect to the system security level.

When the loading parameter λ_c reaches its maximum limit, which in Fig. 3 corresponds to $\omega > 0.85$, LMPs decrease below the minimum power supply price bid of 7 \$/MWh (see Table V in the Appendix). The reason for this behavior is that the OPF VS constraints force the system to the power levels needed to maintain the required maximum loading margin, regardless of the social benefit (notice that only the cheapest supplier, i.e. GENCO 3, provides for the required losses and power demands, as expected). Solutions characterized by $\lambda_c = \lambda_{c_{\max}}$ would likely be unacceptable for the market participants, since the total transaction level as well as LMPs are too low. However, not imposing any maximum limit on λ_c would lead to market solutions with zero power bids ($P_S = P_D = 0$), which

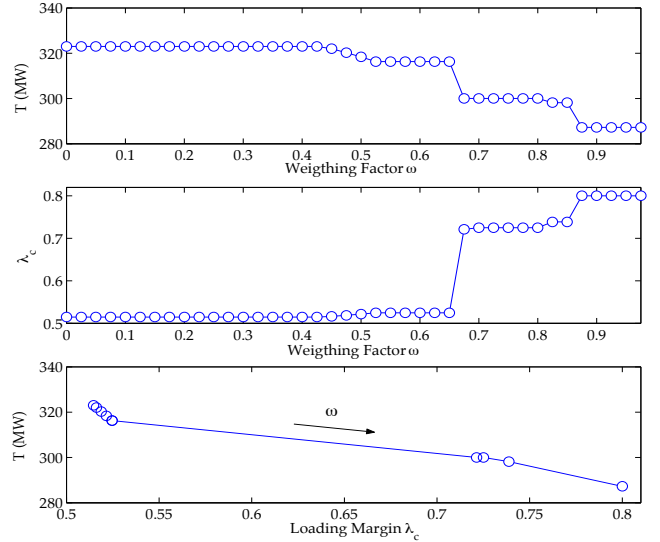
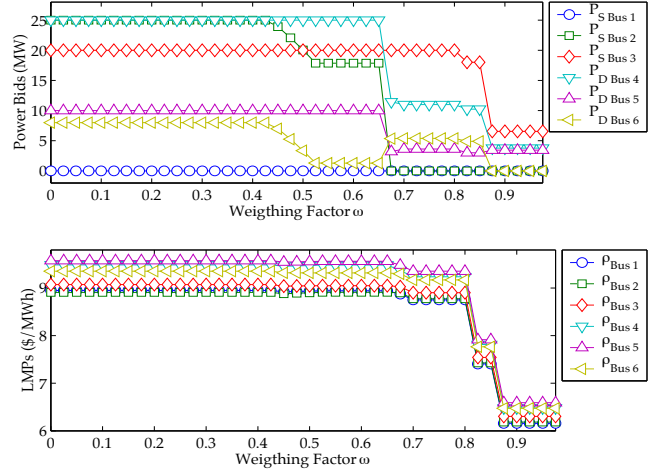
Fig. 2. Total transaction level T and loading margin λ_c for the 6-bus test system with elastic demand.Fig. 3. Power bids P_S and P_D and LMPs ρ for the 6-bus test system with elastic demand.

basically correspond to the base case operating condition associated with the given fixed generation P_{G_0} and load P_{L_0} . Observe that the proposed methodology is designed to give operators and market participants a series of solutions to allow them to analyze the effect of system security on power bids and vice versa, so that proper operating and bidding decisions can be made.

When the transaction level is fixed, as in the case of inelastic demand, imposing a higher security level would result in price increases [7]. This is illustrated in Figs. 5 and 6 for the 6-bus test system assuming inelastic loads; load demands are assumed to have the same values as those depicted in Table II, so that these figure can be compared to the corresponding Figs. 2 and 3. Observe that as ω increases, the security level λ_c and associated LMPs increase, as expected, leading to higher congestion prices.

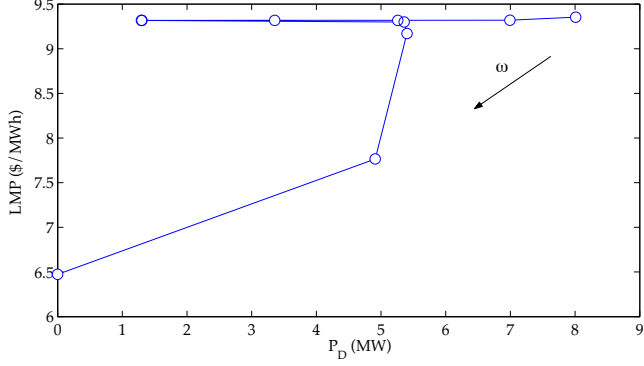

Fig. 4. LMP at Bus 6 as a function of its power demand (ESCO 3) for the 6-bus test system with elastic demand.

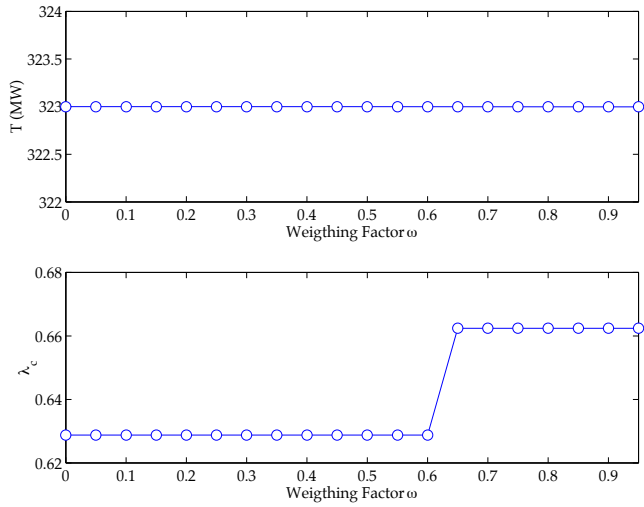

Fig. 5. Power bids P_S and P_D and LMPs ρ for the 6-bus test system with inelastic demand.

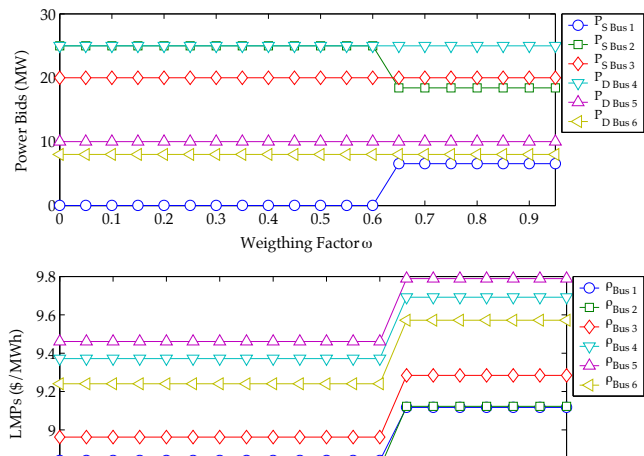

Fig. 6. Power bids P_S and P_D and LMPs ρ for the 6-bus test system with inelastic demand.

B. 129-bus Italian HV Transmission System

For the last three years, the Italian power system has been subjected to a deregulation process, which has forced ENEL, the main Italian electricity company, to be divided in three independent companies (generation, transmission, and distribution) and sell part of its generation plants to private firms. In 1999, an Italian independent system operator (Gestore Rete Trasmissione Nazionale, GRTN) was created to coordinate a competitive electricity market and ensure secure operation of the transmission grid. The Italian electricity market is expected to come on line in 2003 based on a zonal pricing model. The deregulation process and the overall increase in the power consumption forecasted for the near future make the Italian system particularly interesting for market and security studies.

Figure 7 depicts the complete 129-bus Italian 400 kV transmission grid. In the simulations presented here, it has been assumed that 32 generators and 82 consumers participate in the market auction. Usually, Italy imports about the 10% of its power demand from France and Switzerland, hence power supply bids were assumed at the interties. All bids were based on prices around 30-40 US\$/MWh, which are the average prices over the last few years in other European countries where electricity markets are currently in operation, and considering the actual operating costs of thermal plants (55% of the electrical energy produced in Italy is thermal). Fixed generation P_{G_0} and fixed loads P_{L_0} were assumed to be about 80% of the average consumption of a typical working day, since only 20% of ENEL's generation has been sold so far. Power bid levels were chosen to be about 40% of the average consumption in order to force system congestion. All system data and security constraints, i.e. voltage limits, generation reactive power limits and transmission line thermal limits, were provided by CESI, the Italian electrical research center.

Tables III and IV show the results of both OPF solutions (1) and (2) with $\omega = 10^{-3}$ (VS-constrained OPF) for some market participants that are representative of all the areas in which the Italian system is geographically subdivided). As in the case of the 6-bus test system, the proposed method provides a higher total transaction level T , a better distribution of LMPs, and a lower total payment to the system operator (Pay_{GRTN}). Observe that the increased transaction level results also on higher power imports from the interties in Table III and IV (e.g. Villardoin and Lavorges), as expected, since neighboring countries typically generate electricity at lower prices (nuclear plants).

Figure 8 shows the total transaction level T and the loading margin λ_c as a function of the weighing factor ω . As it can be observed, only for $\omega > 0.75$, the security component of the objective function has an influence in the OPF solutions, due to the multi-objective function scaling. As expected, the transaction level is higher for lower values of security, and it decreases as ω increases to yield a larger loading margin (reduce congestion).

Figures 9 and 10 depict some significant power supplies and demands together with their corresponding LMPs,

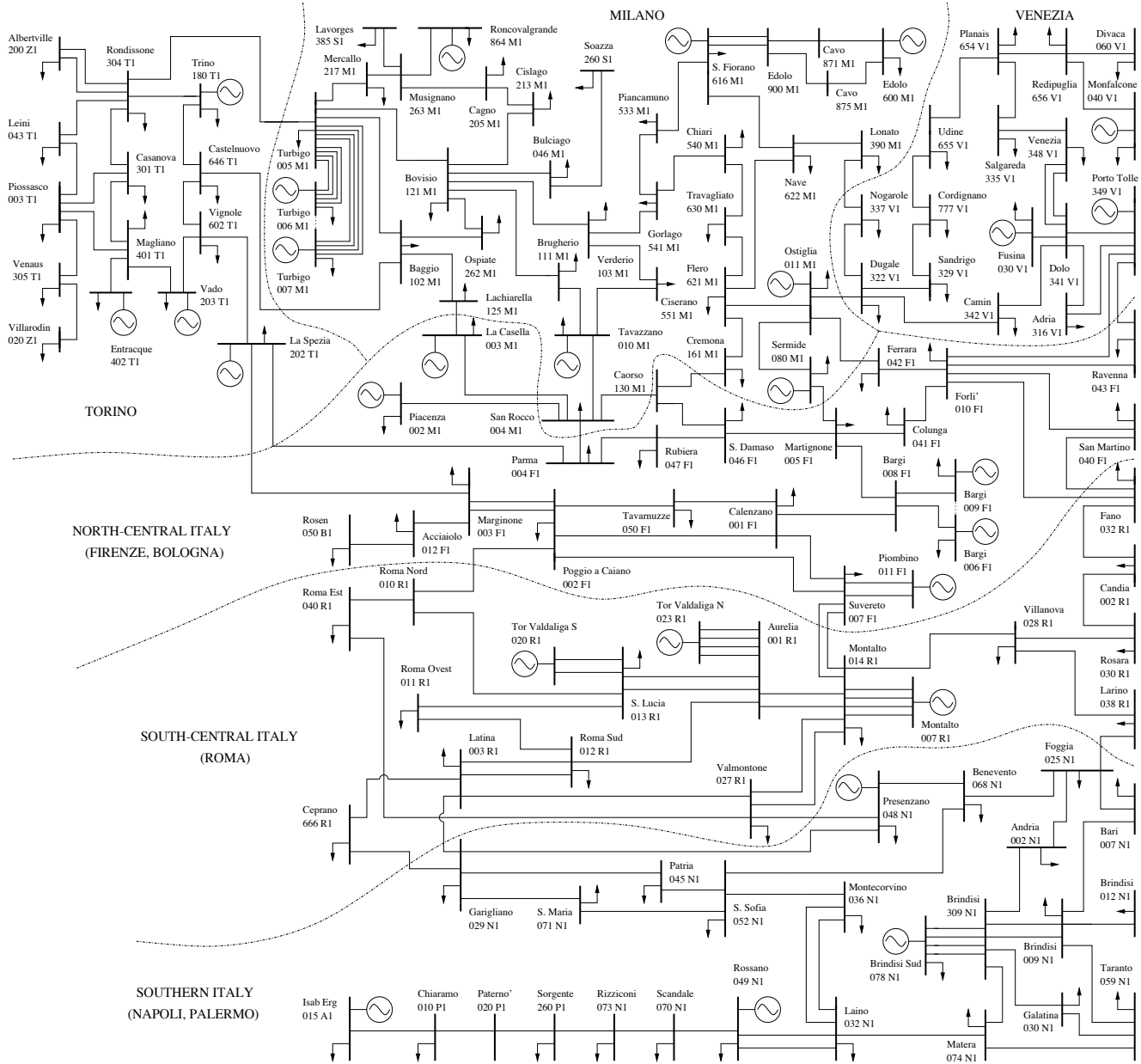

Fig. 7. 129-bus Italian 400 kV transmission system (most of this information is publicly available at the GRTN web site www.grtn.it).

TABLE III

ITALIAN SYSTEM EXAMPLE: OPF WITH OFF-LINE POWER FLOW LIMITS

Participant	V [p.u.]	ρ [\$/MWh]	P_{BID} [MW]	P_0 [MW]	Pay [10^3 \$/h]
Trino	1.1316	33.6	221	266	-16.4
Tavazzano	1.1297	34.3	0	879	-30.1
Turbigo	1.1289	34.1	413	764	-40.1
Fusina	1.1316	34.6	756	77	-28.8
Villarodin	1.1316	32.0	127	541	-21.4
Lavorges	1.1316	32.0	133	451	-18.7
S. Sofia	1.0685	35.2	39	307	12.2
Galatina	1.1203	35.2	119	191	10.9
Colunga	1.1111	31.4	131	210	10.7
Roma O.	1.0839	34.8	207	330	18.7
TOTALS	$T = 24.8$ GW Losses = 135 MW		Pay _{GRTN} = 13.8 10^3 \$/h MLC = 27.8 GW		

TABLE IV

ITALIAN SYSTEM EXAMPLE: VS-CONSTRAINED OPF

Participant	V [p.u.]	ρ [\$/MWh]	P_{BID} [MW]	P_0 [MW]	Pay [10^3 \$/h]
Trino	1.1316	33.3	280	266	-18.2
Tavazzano	1.1316	34.5	0	879	-30.3
Turbigo	1.1316	34.2	753	764	-51.9
Fusina	1.1316	34.1	884	77	-32.8
Villarodin	1.1316	33.4	223	541	-25.5
Lavorges	1.1316	34.1	186	451	-21.7
S. Sofia	1.1005	35.1	192	307	17.5
Galatina	1.1268	34.2	83	191	93.7
Colunga	1.1096	34.7	132	210	11.9
Roma O.	1.1026	34.7	204	330	18.5
TOTALS	$T = 26.1$ GW Losses = 164 MW		Pay _{GRTN} = 13.2 10^3 \$/h MLC = 28.7 GW		

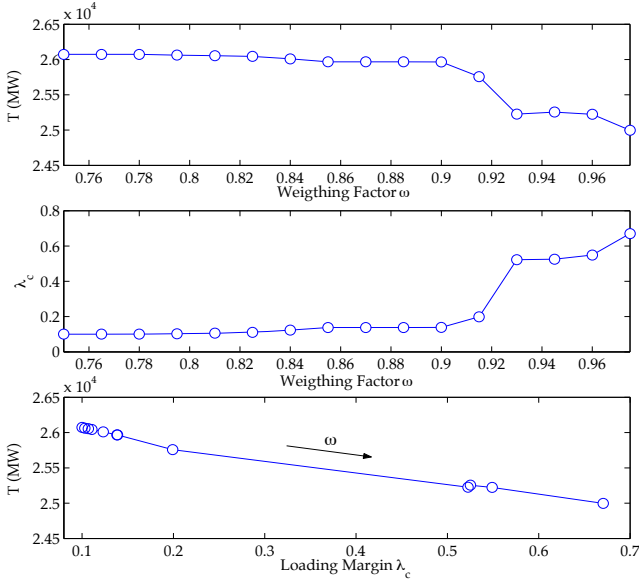

Fig. 8. Total transaction level T and loading margin λ_c for the Italian system example.

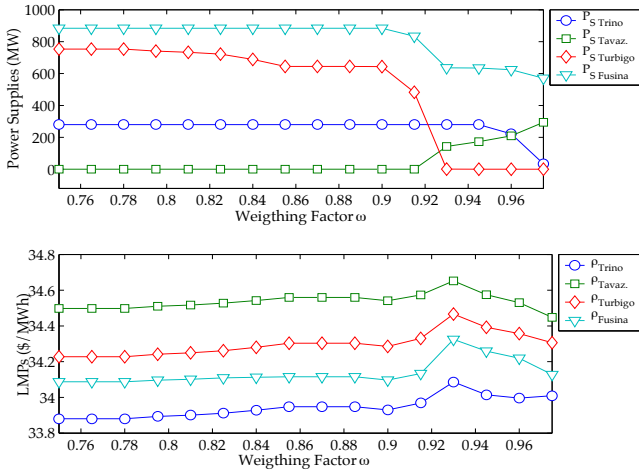

Fig. 9. Most significant power supplies P_S and their corresponding LMPs for the Italian system example.

showing a similar behavior as in the case of the simple 6-bus test system. Once again, increasing the security level of the overall system does not necessarily imply that all power bids decrease. In this example, the LMPs may also increase for higher values of the weighting factor, confirming the results obtained for the 6-bus test system, as some generators and/or loads may be penalized whereas others may benefit as a result of increasing security levels (reduce transmission congestion). Figure 11 depicts the behavior of the LMP at the Galatina bus as a function of the correspondent local power demand, showing once again the unpredictable behavior of the quantity-price pair as the security level varies.

IV. CONCLUSIONS

In this paper, a multi-objective optimization for managing and pricing voltage stability is proposed and tested on

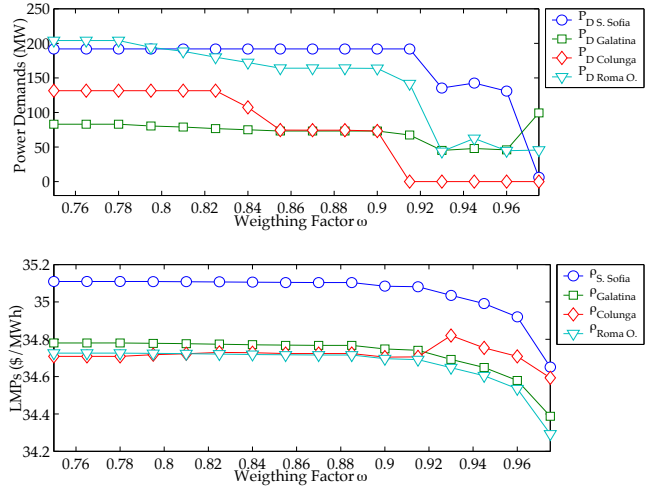

Fig. 10. Most significant power demands P_D and their corresponding LMPs for the Italian system example.

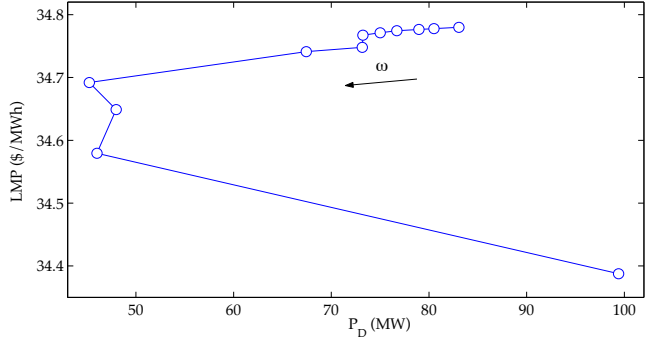

Fig. 11. LMP as a function of power demand P_D at the Galatina bus.

a simple test system as well as on a realistic network. The results obtained with the proposed technique, when compared to those obtained by means of a typical OPF-based market model, show that proper representation of system security actually results in more secure and overall better transactions, since security margins and transaction levels increase, while locational marginal prices improve.

The proposed multi-objective OPF method allows market operators and participants to directly control the desired level of system security by controlling the weighting factors of the different objective functions, which is not possible in typical security constrained OPF-based market implementations.

Further research work will concentrate in modifying the proposed OPF technique to directly include (N-1) contingency computations in the OPF problem as well as to account for other system constraints, such as minimum up and down times for generators.

V. ACKNOWLEDGEMENTS

The authors wish to thank Dr. M. Pozzi and Mr. A. Danelli from CESI for providing the Italian system data and for their helpful comments.

REFERENCES

- [1] M. Huneault and F. D. Galiana, "A Survey of the Optimal Power Flow Literature," *IEEE Trans. Power Systems*, vol. 6, no. 2, pp. 762–770, May 1991.
- [2] J. A. Momtaz, S. X. Guo, E. C. Ogbuobiri, and R. Adapa, "The Quadratic Interior Point Method solving Power System Optimization Problems," *IEEE Trans. Power Systems*, vol. 9, no. 3, pp. 1327–1336, Aug. 1994.
- [3] V. H. Quintana and G. L. Torres, "Nonlinear Optimal Power Flow in Rectangular Form via Primal-Dual Logarithmic Barrier Interior Point Method," Tech. Rep., University of Waterloo, 1996, Technical Report 96-08.
- [4] V. H. Quintana and G. L. Torres, "Introduction to Interior-Point Methods," in *IEEE PICA*, Santa Clara, CA, May 1999.
- [5] G. D. Irisarri, X. Wang, J. Tong, and S. Mokhtari, "Maximum Loadability of Power Systems using Interior Point Nonlinear Optimization Method," *IEEE Trans. Power Systems*, vol. 12, no. 1, pp. 162–172, Feb. 1997.
- [6] C. A. Cañizares, "Applications of optimization to voltage collapse analysis," in *IEEE-PES Summer Meeting*, San Diego, USA, July 1998.
- [7] W. Rosehart, C. A. Cañizares, and V. Quintana, "Costs of voltage security in electricity markets," in *Proc. 2001 IEEE-PES Summer Meeting*, Seattle, WA, USA, July 2000.
- [8] C. A. Cañizares, W. Rosehart, A. Berizzi, and C. Bovo, "Comparison of voltage security constrained optimal power flow techniques," in *Proc. 2001 IEEE-PES Summer Meeting*, Vancouver, BC, Canada, July 2001.
- [9] M. Madrigal and V. H. Quintana, "Optimal day-ahead network-constrained power system's market operations planning using an interior point method," in *IEEE Canadian Conference on Electrical and Computer Eng.*, May 1998, vol. 1, pp. 388–401.
- [10] M. Madrigal, *Optimization Model and Techniques for Implementation and Pricing of Electricity Markets*, Ph.D. thesis, University of Waterloo, Waterloo, ON, Canada, 2000.
- [11] C. A. Cañizares, H. Chen, and W. Rosehart, "Pricing system security in electricity markets," in *Proc. Bulk Power systems Dynamics and Control-V*, Onomichi, Japan, Sept. 2001.
- [12] K. Xie, Y.-H. Song, J. Stonham, E. Yu, and G. Liu, "Decomposition Model and Interior Point Methods for Optimal Spot Pricing of Electricity in Deregulation Environments," *IEEE Trans. Power Systems*, vol. 15, no. 1, pp. 39–50, Feb. 2000.
- [13] B. S. Gisin, M. V. Obessis, and J. V. Mitsche, "Practical methods for transfer limit analysis in the power industry deregulated environment," in *Proc. PICA IEEE International Conference*, 1999, pp. 261–266.
- [14] "Voltage Stability Assessment: Concepts, Practices and Tools," Special publication, IEEE/PES Power System Stability Subcommittee, Final Document, Aug. 2002, available at <http://www.power.uwaterloo.ca>.
- [15] W. Rosehart, C. A. Cañizares, , and V. H. Quintana, "Optimal power flow incorporating voltage collapse constraints," in *Proc. 1999 IEEE-PES Summer Meeting*, Edmonton, Alberta, July 1999.
- [16] E. E. El-Araby, N. Yorino, H. Sasaki, and H. Sugihara, "A hybrid genetic algorithm/SLP for voltage stability constrained VAR planning problem," in *Proc. Bulk Power systems Dynamics and Control-V*, Onomichi, Japan, Sept. 2001.
- [17] H. A. Eiselt, G. Pederzoli, and C.-L. Sandblom, *Continuous Optimization Models*, de Grueter, New York, 1987.
- [18] G. B. Sheblé, *Computational Auction Mechanism for Restructured Power Industry Operation*, Kluwer Academic Publishers, 1998.

APPENDIX

This appendix depicts the complete data set for the 6-bus test system of Fig. 1. Table V shows supply and demand bids and the bus data for the market participants, whereas Table VI shows the line data. Maximum active power flow limits were computed off-line using a continuation power flow with generation and load directions based on the corresponding power bids, whereas thermal limits were assumed to be twice the values of the line currents at base load conditions for a 400 kV voltage rating. In

TABLE V

GENCO AND ESCO BIDS AND BUS DATA FOR THE 6-BUS TEST SYSTEM

Participant	C [\$/MWh]	P_{\max}^{bid} [MW]	P_{L_0} [MW]	Q_{L_0} [MVar]	P_{G_0} [MW]	$Q_{G_{\text{lim}}}$ [MVar]
GENCO 1	9.7	20	0	0	90	± 150
GENCO 2	8.8	25	0	0	140	± 150
GENCO 3	7.0	20	0	0	60	± 150
ESCO 1	12.0	25	90	60	0	0
ESCO 2	10.5	10	100	70	0	0
ESCO 3	9.5	20	90	60	0	0

TABLE VI

LINE DATA FOR THE 6-BUS TEST SYSTEM

Line $i-j$	R_{ij} [p.u.]	X_{ij} [p.u.]	$B_i/2$ [p.u.]	P_{\max} [MW]	I_{\max} [A]
1-2	0.1	0.2	0.02	15.4	37
1-4	0.05	0.2	0.02	50.1	133
1-5	0.08	0.3	0.03	42.9	122
2-3	0.05	0.25	0.03	21.6	46
2-4	0.05	0.1	0.01	68.2	200
2-5	0.1	0.3	0.02	33.6	103
2-6	0.07	0.2	0.025	52.1	132
3-5	0.12	0.26	0.025	26.1	95
3-6	0.02	0.1	0.01	65.0	200
4-5	0.2	0.4	0.04	9.8	26
5-6	0.1	0.3	0.03	2.2	29

Table VI, it is assumed that $I_{ij_{\max}} = I_{ji_{\max}} = I_{\max}$ and $P_{ij_{\max}} = P_{ji_{\max}} = P_{\max}$. Maximum and minimum voltage limits are considered to be 1.1 p.u. and 0.9 p.u.

Federico Milano received in March 1999 the Electrical Engineer degree from the University of Genoa, Italy. Since March 2000, he has been attending the Ph.D course at the Electrical Engineering Department, University of Genoa, in the field of power system control and operation. He is currently working at the Electrical & Computer Engineering Department of the University of Waterloo, Canada, as a Visiting Scholar. His research interests are voltage stability and electricity market.

Claudio A. Cañizares received in April 1984 the Electrical Engineer diploma from the Escuela Politécnica Nacional (EPN), Quito-Ecuador, where he held different teaching and administrative positions from 1983 to 1993. His MS (1988) and PhD (1991) degrees in Electrical Engineering are from the University of Wisconsin-Madison. Dr. Cañizares is currently an Associate Professor and the Associate Chair for Graduate Studies at the E&CE Department of the University of Waterloo, and his research activities concentrate in the study of stability, modeling, simulation, control and computational issues in ac/dc/FACTS systems.

Marco Invernizzi was born in Genoa, Italy, on March 27, 1938. He received the degree in Electrical Engineer from the University of Genoa in 1984, and a PhD in power systems in 1989. Since 1990, he has been working at the Electrical Engineering Department of the University of Genoa, where he is now Associate Professor of Power System Analysis. He is presently engaged in modeling, simulation, management and control of electric energy system in deregulated environments and power system stability assessment.